

## DESIGN AND DEVELOPMENT OF ROTOR PROFILE FOR SCREW PUMP – A REVIEW

Raj H. Joshi<sup>1</sup>, Jay N. Patel<sup>2</sup>, Kandarp M. Patwa<sup>3</sup>, Shivam U. Prajapati<sup>4</sup>,  
Vaishal J. Banker<sup>5</sup>, Harsh B. Joshi<sup>6</sup>

<sup>1,2,3,4</sup> (UG Students, Mechanical Engineering Department, A D Patel Institute of Technology, Anand, Gujarat)

<sup>5,6</sup>(Assistant Professor, Mechanical Engineering Department, A D Patel Institute of Technology, Anand, Gujarat)

---

**ABSTRACT:**Increasing demands for high-performance handling of fluids in oil and gas as well as other applications require improvements of efficiency and reliability of screw pumps. Rotor profile plays the key role in the performance of such machines. Furthermore, nowadays manufacturing industries faces many problems in the manufacturing of profile with varying curves. Positive displacement rotary pumps, such as internal and external gear pump, usually present an variable instantaneous flow rate. This characteristic produces undesirable noise and vibrations. On the other hand, twin-screw pumps and three-screw pumps are usually considered as having a constant instantaneous flow rate. Through comparisons of different geometrical parameters of the pump, i.e., flow area, contact line length per lobe, blow hole area, etc. So, profile generation of rotor for twin-screw pump as well as three-screw pump by considering different parameters is main motive of this paper.

**KEYWORDS:** CREO; MATLAB; Rotor profile; Three-screw pump; Twin-screw pump.

---

### 1. INTRODUCTION

A screw pump is a type of positive displacement pump that uses two or more screws that intermesh to pressurize fluids and move them in a system. The screws take in fluid then push it out from the other side while increasing its pressure. Due to their ability to provide high flow rates even in viscous liquids, screw pumps are ideal for fuel transfer, elevators, and other similar industrial applications. In screw pumps the idler rotors generate a hydrodynamic film which provides radial support similar to journal bearings. Symmetrical pressure loading on the power rotor eliminates the need for radial bearings to absorb radial forces [10]. Positive displacement rotary pumps, such as internal and external gear pumps, usually present an variable instantaneous flow rate. This characteristic produces undesirable noise and vibration [3]. These characteristics are eliminated by screw pump as well as it gives constant flow rate. The main advantages to using screw pumps are [3]: Construction simplicity and working reliability; Quietness at high speeds due to the particular profile which pumps the fluid mainly axially without creating turbulent motion and radial loads on the rotors; Continuous and uniform flux; Auto priming for elevated heights. Different applications are [2]: Oil and gas industries; Marine and shipbuilding industries; Food and beverages industries; Chemical Industries.

#### 1.1 Profile of rotor

Rotor profiles for screw pumps are mainly composed of arcs which could be involute, cycloid or circular, as shown in four different types of screw pump profiles in Figure(1) [2].

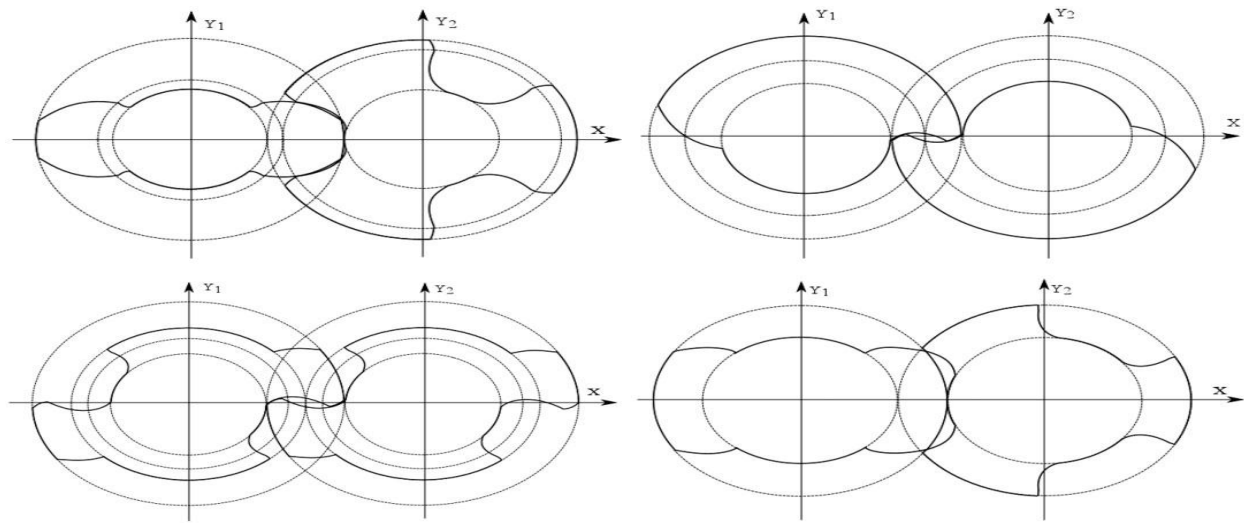

**Figure 1. Four typical rotor profiles for multiphase screw pumps: A-type, B-type, C-type and D-type[2].**

There are various varying profiles of rotor are shown in Figure 1. These profiles are made of various curves vary at some points. In that figure Profile-A is made of involute and cycloidal curves and Profile-D is made of cycloidal curve. Research work on rotor profile design and performance calculation of multiphase twin-screw pumps was reported in many previous studies. The number of literature resources is large and therefore just the most relevant are listed below[2].

Ozf et al introduced the generation and analysis of four typical rotor profiles for marine screw pumps, which are mainly composed of involute and cycloid curves. They mentioned that even though the involute–cycloid screw pumps may not be as volumetrically efficient as cycloid screw pumps, they have higher reliability during operation[12]. Li and Nie et al discussed systematically the structure, rotor profiles generation and performance calculation of different screw pump profiles and optimised some of the profiles to achieve better sealing[10][11]. Optimal rotor profiles will be different for different working conditions.

## 2. LITRETURE REVIEW

Rotor profiles for screw pumps are mainly composed of arcs which could be involute, cycloid or circular. The main constraints which need to be considered during the designing process of a screw pump profile are[2]:

- The rotor profile should satisfy meshing conditions during the working process with conjugate motion and without undercutting.
- The rotor profile should have good sealing property with as small as possible blowhole, and short and continuous contact line.
- The rotor profile should have large flow area to ensure as large as possible mass flow rate.
- The carryover of the designed profile which is the area between two rotors in the default position (shown in Figure) should be as small as possible.
- The rotor profiles should be relatively easy to produce with as low as possible manufacturing costs.

## 2.1 Literature of Twin-Screw pump

A number of profiles for screw pumps have been created to illustrate the ability of the standard screw compressor software to be used in this specific application. The screw pump design imposed the requirement that both rotors must be identical, in order to be manufactured by a single tool. Both rotor and rack generation procedures were used; the first for circular profiles and the latter for involute profiles[1]. The circular profile assures a small blow-hole area. Unfortunately, it retains a high carryover, as is the case for the involute profile and the industrial hook and claw profiles[5]. The trochoidal profile, has a small carry over. However, it has a large blow-hole area. The rotor profile in this twin-screw pump (see-Figure 2) is composed of cycloid and involute curves. The involute-cycloid rotor profile called A-type. Profile is generated by modification of a cycloidrotor profile. The aim of this modification is to increase the flow area and consequently improve performance[2].

Involute  $bc$  Epicycloid  $a_1b_1$  Hypocycloid  $c_1d_1$

Hypocycloid  $cd$  Involute  $b_1c_1$

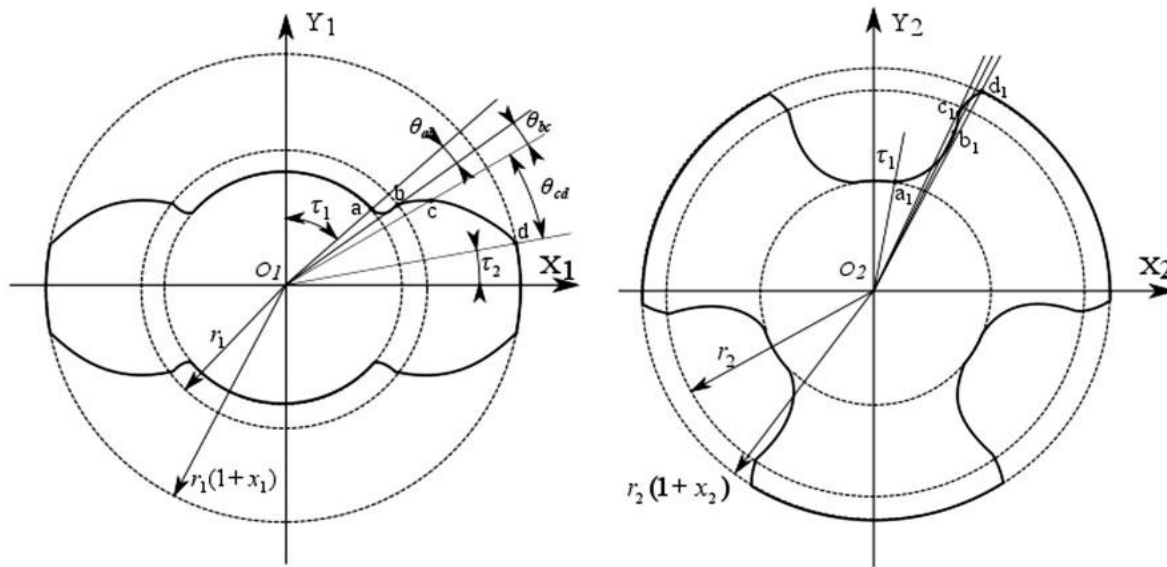
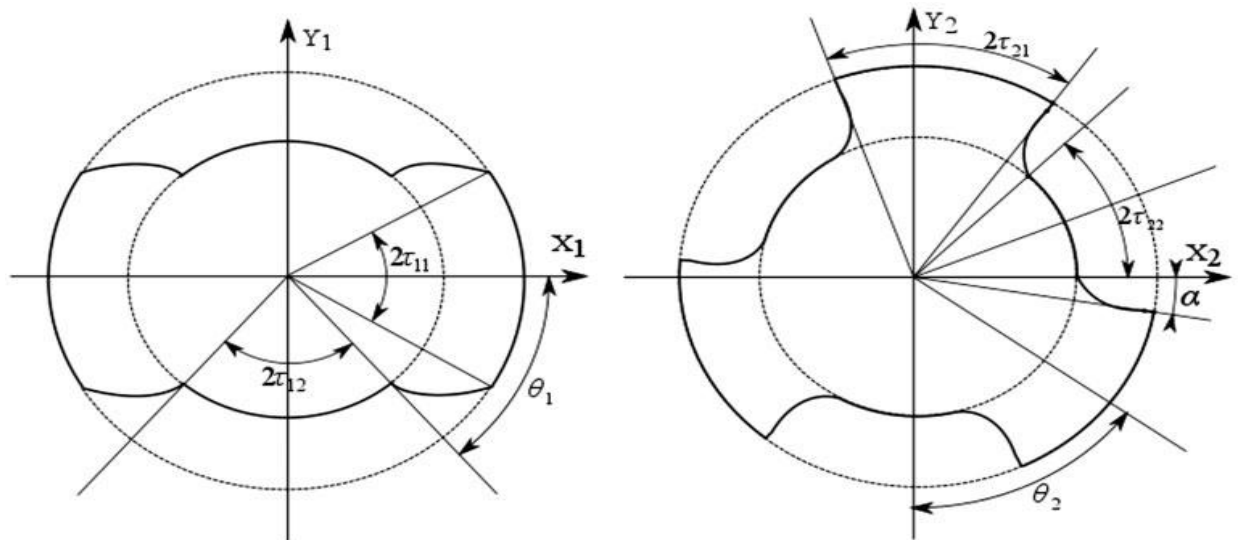

Figure 2. Generation of A-type rotor profile[2]

Figure 3 shows the generation of D-type rotor profile which is mainly composed of cycloid arc and circle arc[2].



**Figure 3. Generation of D-type rotor profile[2]**

The area efficiency is the ratio of the free flow area and the overall cross section area. Large area efficiency leads to large flow passages and large flow rate further down the same diameter and lead. Area efficiency is the main reference index when designing large flow screw pumps. For twin-screw pumps, the area efficiency can be described as follows[2].

$$\eta_a = 1 - \frac{S_m + S_f}{\pi R_1^2 + \pi R_2^2 - S_{abcd}} \quad \dots(1.1)$$

By using equation (1.1), the area efficiency of A-type and D-type rotor profiles can be calculated as:

**Table 1. Area efficiency of A-type and D-type rotor profiles[2].**

	S <sub>m</sub> (mm <sup>2</sup> )	S <sub>f</sub> (mm <sup>2</sup> )	$\pi R_1^2 + \pi R_2^2 - S_{abcd}$ (mm <sup>2</sup> )	Area Efficiency
A-type	7269.23	10631.61	28566.38	37.34%
D-type	10835.49	11019.14	29986.01	27.12%

Table 1 shows that the area efficiency of A-type rotor profile is approximately 1.4 times of D-type, which means theoretically the flow rate of A-type is roughly 1.4 times of D-type when all other rotor parameters are the same. In order to improve the area efficiency of D-type profile, this kind of rotor profile is usually applied in the designing of three-screw pumps, which has a configuration of one male rotor and two relatively smaller female rotors[9].

Blow hole is a leakage area formed between the tips of the two rotors and the housing in the vicinity of the CUSP line, the line which connects two rotor bores. The A-type rotor profile has the largest blow hole area. The overall shape of the blow hole area of rotors with D1 and D2 rotor profiles is similar because these two differ only in the rotor helix angle[2].

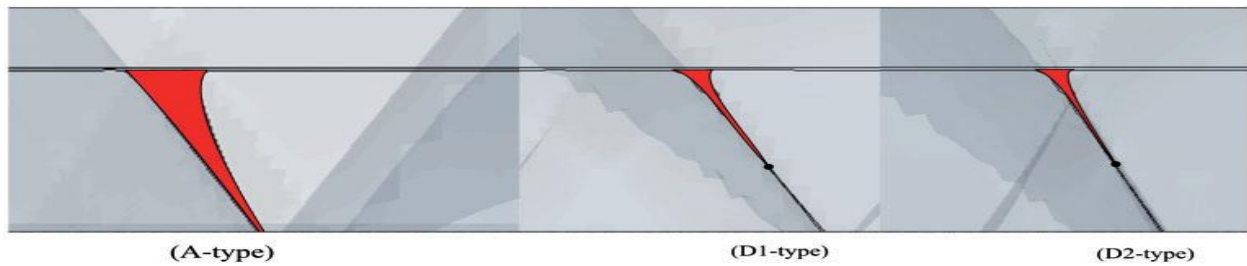

Figure 4. Blowhole of three kinds of rotors[9]

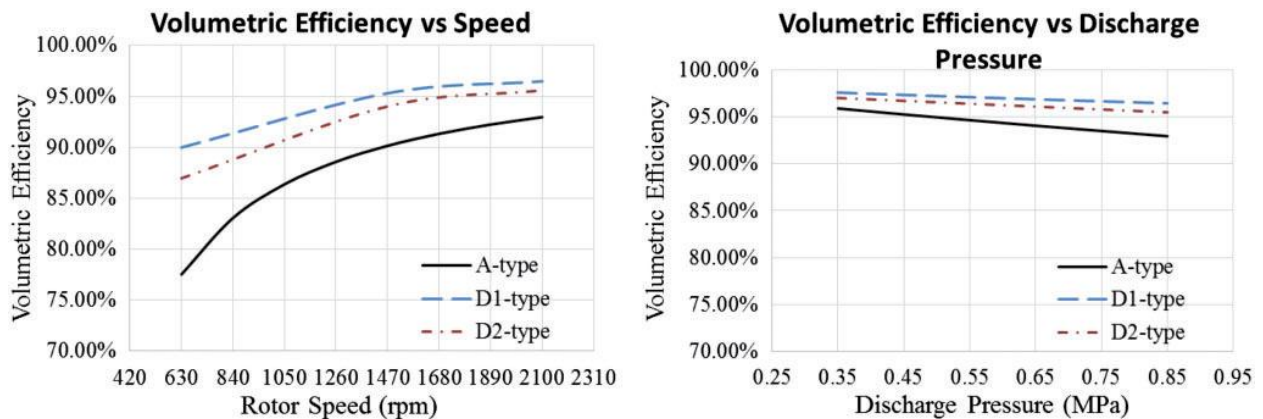

Figure 5. Volumetric efficiency: (left) variable rotational speed; and (right) variable discharge pressure[9]

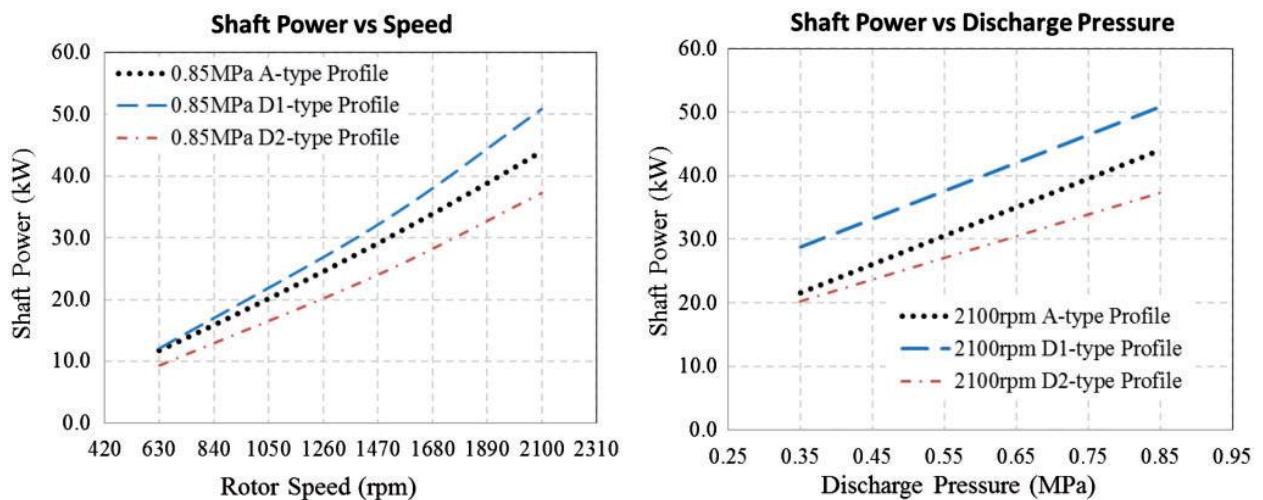

Figure 6. Shaft power: (left) variable rotational speed; (right) variable discharge pressure[9]

The contact line,  $L$ , is composed of three parts: the contact line length of cycloidal segment  $L1$ , the contact line length of pseudo Archimedes segment  $L2$  and the contact line length of arc segment  $L3$ . In reality, there is a carryover between two mated rotors. This means a larger gas may be carried from high-pressure port back to low-pressure port. This phenomenon will lead to larger leakage and reduce the pump performance [4][13].

## 2.2 Literature of Three-Screw pump

For instantaneous flow-rate generation require to introduce some considerations about the geometry of the rotors. Besides it is necessary to identify the parameters that allow a complete characterization of the screws themselves[15]. On the section of the central rotor we may find the two worms with their root  $r$  and tip  $r_e$  radiuses. On the two idler rotors, on the contrary, we observe the two vanes between the tip circle of radius  $r$  and an internal web with radius  $r_i = 2r - r_e$ [15].

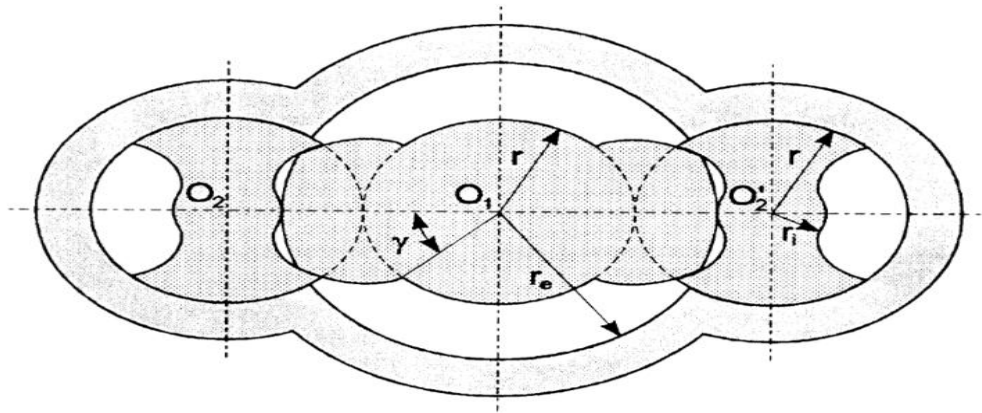

Figure 7. Normal section of a three-screw pump[15]

- Centre screw tracing: - The Point P is rigidly joined to one of the idler rotors the extremity of the vane profile during its relative motion, traces the flank of the central rotor tooth profile. The parametric equation of the curve traced, as a function of the rotation angle  $\alpha_c$  of the idler rotor. The parametric equation of the curve traced, as a function of the rotation angle  $\alpha_c$  of the idler rotor[15].

$$x = 2r \cos \alpha_c - r \cos 2\alpha_c \dots (2.1)$$

$$y = 2r \sin \alpha_c - r \sin 2\alpha_c \dots (2.2)$$

Figure 8.(a) Central rotor and flank rotor

(b)Generated Epicycloid [15]

- Idler rotor tracing: - The Point P is the edge of the worm, with height  $h$ , of the central screw. The curve parametric equation can be obtained by trigonometric considerations[15].

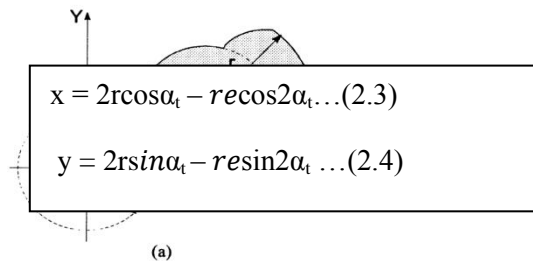

**Figure 9. Idler rotor vane tracing[15]**

The basic principle of all screw pumps is the screw convey or with its typical axial direction of discharge. Among the advantages of this delivery principle are the relative insensitivity to dirt, insensitivity to viscosity, low-turbulence delivery of the fluid, and largely pulsation-free and thus low-noise delivery. The single-screw pump has gained worldwide importance for the transfer of plastic melts in what is commonly called an extruder[22].When fluid media internal friction forces are insufficient for producing any significant pressure, sealing in a pump must be created between the delivery pressure and suction chambers by adding one or more sealing screws. For this reason, the following sealing conditions must be observed[22]:

$$ZA - np (2p) + np = 0$$

Where

ZA = Number of threads of the driving screw

Zp = Number of threads of each sealing screw

np = Number of sealing screws

In the year 2013, the mathematical model of rotor profile and a new edge blunting method of the three screw pump rotor with an elliptic arc and equations of the rotor profile after edge blunting was determined. Through compression of different geometrical parameter of pump. i.e., flow area, contact line length per lobe, blowhole area, etc. The new streamlined profile, with significantly smaller blowhole area, is reference significant for the optimization design. The new profile is proved to be better than the existing profiles of the three screw pump. The theoretical profile of driven rotor consists of three segments: (1). a dedendum circle (2). a cycloidal curve (3). a addendum circle. The cycloidal curve is an extended epicycloids , generated as the trajectory of point M rigidly connected to the circle O1 that rolls over circle O2, N is the intersection point of the epicycloid, (a). with the addendum circle, (b). and the angle at this point between the two limiting rays of the two arcs is 61.87 deg[19].Edge blunting is carried out for two reasons: the meshing point is moved from the outer circumference to be more durable and angle  $\beta$  at the transition point is enlarged to make the profile less sharp[19].

• There are two types of edge blunting

1) Edge blunted by a line

2) Edge blunted by a circle

The profile of thre-screw pump is characterized by a favorable proportion of the delivery cross-sectional area to the material cross-sectional area, Of course, sufficient strength and rigidity of the sealing screws must be ensured. The sealing screws, also called working screws, rotate virtually torque-free. The driving screw is not exposed to radial forces, which gives the pump a favorable overall efficiency. The flanks of the working screws are formed by elongated epicycloids and the flanks of the driving screw constitute shortened epicycloids. Double-line sealing is

achieved by axially extending the driving screw which, in turn, imparts high volumetric efficiency to the pump. The profile is designed so that only the driving screw delivers pressure, whereas the two working screws are driven by the liquid pressure. Except for friction, there is no power transmitted from the driving screws onto the working screws. Thus, war of the screw flanks is almost non-existent[23].

### **3.OUTCOMES AND FUTURE SCOPE**

The performance of screw pump is depend on various parameters including rotor profile, it's found that the performance is mainly depend on rotor profile. Furthermore, in twin-screw pump both rotors are of same profile, but this is opposite in three-screw pump. Intrstingly, the type-A profile (involute cycloidal profile) is use in twin-screw pump while type-D profile (circular cycloidal profile) is use in three-screw pump. Moreover, the flow rate or overall performance of the screw pump is totally dependent on the screw rotor profile geometry. The stepwise method for designing the profile of triple screw rotor pump, which includes generation of the pitch as the first step. Conventional design is based on circular pitch, but it is possible to increase the pumping ratio of a triple screw rotor pump by adopting the non-linearpitch, as the pumping ratio is mainly governed by the generic design parameters: the pitch non-circularity and screw rotor non-linear. In future, weimproving the profile of triple screw rotor pump as well as twin screw rotor pump to reduce the losses for different types of gaps, which may result in increase of volumetric efficiency. We can do CFD analysis of the both type of pump for the given profiles and test these pump for different viscous fluids like grease, tomato ketchup, engine oil, furnace oil, lubrication oil, synthetic oil etc.

### **REFERENCE**

- [1].Stosic, N., Smith, I. K., Kovacevic, A., & Mujic, E. (2006). Vacuum and multiphase screw pump rotor profiles and their calculation models. *VDI BERICHTE*, 1932, 53.
- [2].Yan, D., Tang, Q., Kovacevic, A., Rane, S., & Pei, L. (2018). Rotor profile design and numerical analysis of 2–3 type multiphase twin-screw pumps. *Proceedings of the Institution of Mechanical Engineers, Part E: Journal of Process Mechanical Engineering*, 232(2), 186-202.
- [3].Mimmi, G., & Pennacchi, P. (1970). Design of three-screw positive displacement rotary pumps. *WIT Transactions on Engineering Sciences*, 7.
- [4].Xu, J., Feng, Q., & Wu, W. (2011). Geometrical design and investigation of a new profile of the three screw pump. *Journal of Mechanical Design*, 133(9).
- [5].Lu, Y., Guo, B., & Geng, M. F. (2015). Study on design of rotor profile for the twin screw vacuum pump with single thread tooth. In *IOP Conference Series: Materials Science and Engineering (Vol. 90, No. 1, p. 012007)*. IOP Publishing..
- [6].PATEL, N. M., SHAH, B., & RAMAN, A. DESIGN AND ANALYSIS FOR SCREW COMPRESSOR.
- [7].Stosic, N., Smith, I. K., Kovacevic, A., & Mujic, E. (2006). Vacuum and multiphase screw pump rotor profiles and their calculation models. *VDI BERICHTE*, 1932, 53.



- [8].El- Sadi, H., &Esmail, N. (2005). *The Effects of Screw Geometry on the Pumping Efficiency of Micro- Screw Pump. The Canadian Journal of Chemical Engineering*, 83(6), 944-950.
- [9].Stosic, N., Smith, I., &Kovacevic, A. (2005). *Screw compressors: mathematical modelling and performance calculation. Springer Science & Business Media.*
- [10].HU, B., WANG, W. Y., LI, Q. G., WANG, K., & Cao, F. (2011). *Numerical Simulation on Pressure Distribution of Twin-screw Multiphase Pump [J]. Fluid Machinery*, 10.
- [11].Nie, S. B., Li, F. T., Lv, W. L., FENG, Y. H., & GUO, D. Q. (2009). *Improvement and hermeticity analysis of B-type double screw pump curve. Mechanical and Electrical Equipment*, 5.
- [12].Ozf A, et al. *Marine screw pump. Hefei: Hefei General Machinery Research Institute*, 1969.
- [13]. Wu, Y. R., and Fong, Z. H., (2008), "Rotor Profile Design for the Twin-Screw Compressor Based on the Normal-Rack Generation Method," *ASME J. Mech.Des.*, 130(4), p. 042601.
- [14].Wei, J., Sun, X., Sun, W., & Zhang, G. (2013). *Rotor profiles design method and numerical simulation for twin-screw kneader. JixieGongchengXuebao(Chinese Journal of Mechanical Engineering)*, 49(3), 63-73.
- [15].Mimmi, G., &Pennacchi, P. (1970). *Design of three-screw positive displacement rotary pumps. WIT Transactions on Engineering Sciences*, 7.
- [16].Mimmi, G., &Pennacchi, P. (1997). *Determination of tool profile for the milling of three-screw pump rotor. Meccanica*, 32(4), 363-377.
- [17].Mimmi, G., &Pennacchi, P. (1997). *Deviations induced by tool sharpening in the profile of three screw pump rotors. Meccanica*, 32(6), 567-576.
- [18].Litvin, F. L., & Feng, P. H. (1997). *Computerized design, generation, and simulation of meshing of rotors of screw compressor. Mechanism and Machine Theory*, 32(2), 137-160.
- [19]. Xu, J., Feng, Q., & Wu, W. (2011). *Geometrical design and investigation of a new profile of the three screw pump. Journal of Mechanical Design*, 133(9), 094501.
- [20].Mimmi, G. C., &Pennacchi, P. E. (1998). *Computation of pressure loads in three screw pump rotors. Transactions- American Society Of Mechanical Engineers Journal Of Mechanical Design*,120, 581-588.
- [21].Mimmi, G. C., &Pennacchi, P. E. (1998). *Dynamic effects of pressure loads in three screw pump rotors. Journal of Mechanical Design*, 120(4), 589-592.
- [22].Stosic, N., Smith, I. K., Kovacevic, A., &Mujic, E. (2011). *Geometry of screw compressor rotors and their tools. Journal of Zhejiang University-Science A*, 12(4), 310-326.
- [23]. Wegener, J., &Cozza, W. E. (1985). *Screw pumps of one, two and three screw design. In Proceedings of the Second International Pump Symposium (pp. 41-46).*

[24]. Hsieh, C. F., & Hwang, Y. W. (2008). *Tooth profile of a Roots rotor with a variable trochoid ratio. Mathematical and Computer Modelling, 48(1), 19-33.*