

Effect of Wind Direction through Double Storied Building Model Configurations in Wind Tunnel

Dr.Krishna M. K*¹, Dr.Mahalingegowda R. M²

¹Professor in department of Civil Engineering, S.J.B Institute of Technology
Bengaluru –560060, Karnataka, INDIA.

²Professor in department of Civil Engineering, P. E. S. College of Engineering,
Mandya –571401, Karnataka, INDIA.

ABSTRACT: Effect of wind direction on plume dispersion around urban buildings has been investigated by physical modelling using arrays of buildings- like obstacles at scale 1:100 in boundary layer wind tunnel for double storied buildings and compared with field data. The particular effect of obstacle width- to - height ratio (S/H) was examined for a fixed obstacle plan area density. Series of experiments have been carried out in which the wind direction varied in steps of 5° for selected orientation of line source at 90° , 95° , 100° and 105° . Further, from the observation, it was concluded that the maximum lateral concentration shift to upward the wind direction of line source is increased for inline double storied buildings model configuration. It can be concluded, the wind tunnel results showed that concentrations at downwind distances decreased as the wind direction increases (positive values) for measured orientation of line source in inline double storied buildings model configuration. In comparison, experimentally observed σ_z values are below the field values. They were best fitted with power-law profiles. The non-dimensional concentration for both the field and wind tunnel results of double storied inline buildings configuration seems to be more or less uniform. Values of vertical spread parameters for double storied inline array configuration and field data were followed a similar trend but inline array configuration of double storied buildings model, non-dimensional concentrations were typically twice larger compared to the field data. This is attributed to the fact that the tracer material is quite concentrated in the recirculation region in inline array configuration of the double storied buildings model.

Key words: Atmospheric boundary layers, Wind tunnel study, Vehicular emission dispersion, Array of building obstacles. Effect of wind direction.

I. INTRODUCTION

Atmospheric conditions such as wind speed, wind direction, and air temperature gradients interact with the physical features of the landscape to determine the movement and dispersal of air pollutants. The problem of near field plume dispersion in the urban environment is quite complex and involves the details of the interaction of the plume and the flow field with several obstacles. This type problem is not generally solvable by computational means and thus physical modeling is the best way to obtain sensible results and to study the influence of the various parameters relevant to the problem. While using any line source model for prediction of pollutants in any urban/suburban area, it is imperative that the model should be capable of accounting for building effects. There is greater scope to understand systematically the influences of important varying parameters on dispersion mechanisms through arrays of obstacles. For the study of these types of local parametric influences, a boundary layer wind tunnel is a convenient tool to investigate the effects of these potential parameters.

Dispersion is dependent on various source parameters and surface layer micro-meteorological parameters such as wind speed, wind direction, roughness conditions etc. In addition, the influence of the nearby buildings and other structures of varying terrain categories cause further complexity in the dispersion phenomenon. Hosker (1984), Hunt (1975) and Meroney (1995) have discussed the complex diffusion mechanisms in the wake of building arrays. Until fairly recently the literature on this topic has been quite sparse; for example the review by Hosker (1984) was mainly concern with flow and dispersion around individual or small groups of obstacles, with only handful of relevant field and wind tunnel experiments have appeared.

Meroney (1995) and Hosker (1984) provided excellent reviews on the main characteristics of flow and dispersion around single or small groups of obstacles. Several experiments have been carried out in model and real urban canopies and wind tunnel using tracer gases. Davidson et al. [1995], Theurer et al. (1996), and Macdonald et al. (1998) investigated diffusion around a building in field experiment in suburban area in Sapporo. They found that high concentrations were observed both upwind and downwind of the source on the

roof. Macdonald et al. (1998) confirmed that at short distances from the source, concentration profiles in the obstacle arrays are quite variable. Mavroidis and Griffiths (1996) examined the flow and dispersion through arrays of obstacles. The results suggested that enhanced mixing and dispersion occur within array. Recently, dispersion of atmospheric pollutants in the vicinity of isolated obstacles of different shape and orientation with respect to the mean wind direction has been examined in scaled field and wind tunnel experiments. It has been found that the presence of taller obstacles results in a reduction of ground level concentrations. It is now widely acknowledged that the greatest damage to human health is caused in the near- field of toxic releases from line sources within the urban region. Complex flows around the obstacles in urban canopy pose difficult challenges to research with change in wind direction. Thus, it is essential to address these challenges and develop methods to model the impact of contaminants at short distance from the source within urban region with different wind direction

The main aim of the present paper is to investigate experimentally, effects of the wind direction on vehicular emission (which are treated as line source) dispersion phenomenon in simulated terrain conditions and to understand the dispersion pattern through double storied building model configurations in the near- field of roadway. Experiments have been carried out in which the wind direction varied in steps of 5° for selected orientation of line source at 90° , 95° , 100° and 105° .

II. EXPERIMENTAL SETUP

2.1. Simulation of ABL Flow

Artificially thickened Atmospheric Boundary Layers (ABLs) have been produced in the Environmental Wind Tunnel (EWT) by the combination of the passive devices such as Counihan's spires, tripping barrier and roughness blocks on the wind tunnel floor. The entire floor of the EWT was covered with roughness elements of $23 \times 23 \times 23$ mm with a spacing of 70 mm (ABL-I). Three number of elliptic vortex generators (Counihan spires) of 940 mm height were placed symmetrically at the entrance of the test section of EWT with roughness elements (ABL-II). Further, a tripping barrier of 300 mm high was placed after the Counihan spires at 1.25 m from the Counihan spires with roughness elements (ABL-III). The design of cubical blocks has been carried out as per Counihan (1969), Gartshore and De Cross (1977) Gowda (1999).

2.2. Details of physical modelling dispersion experiments

In the present study a near-field terrain inline buildings model arrangements have been selected. The set of experiments were carried for a geometric model scale of 1:100, which represent a real buildings height of 7 m (double storied buildings). Physical modelling dispersion experiments were carried out one of the simulated ABL-III which represent centre of large city in the near field of roadway in the EWT. Measurements were taken to obtain vertical tracer gas concentration profiles for double storied building at pre-selected downwind distances from centre of the line source as per the scheme shown in Fig. 1. These measurements were observed at selected vertical height of (1.4H, 2.9H and 4.2H) for double storied buildings model for selected lateral width of tunnel from the tunnel floor.

Lateral concentration measurements (along width of the test section) for pre selected lateral width of 4H, 8H, and 12H for double storied buildings model for all the downwind distances on either sides of the centreline as per the scheme shown in Fig. 2. Series of experiments have been carried out in which the wind direction varied in steps of 5° for selected orientation of line source at 90° , 95° , 100° and 105° as per the scheme shown in Fig 3.

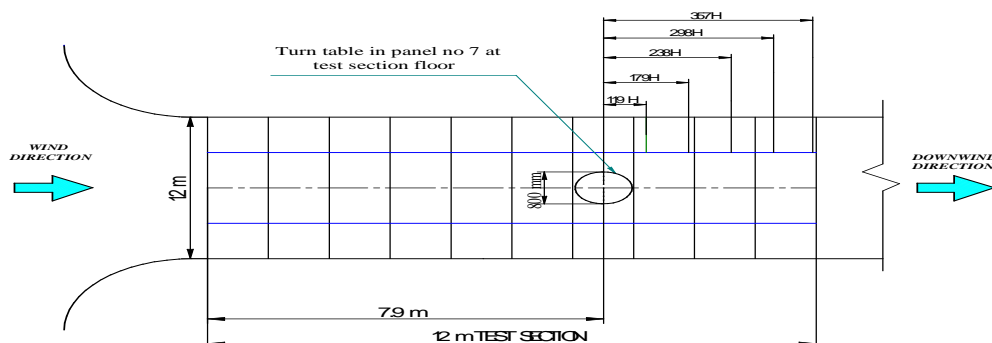

Fig. 1: Schematic showing downwind distances for tracer gas concentration measurement in the EWT

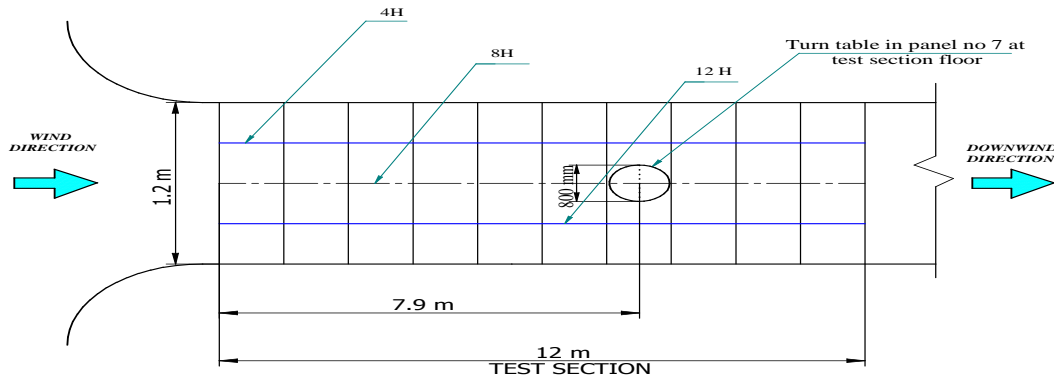

Fig. 2: Schematic showing concentration measurements for pre-selected lateral width in EWT for the double storied buildings model

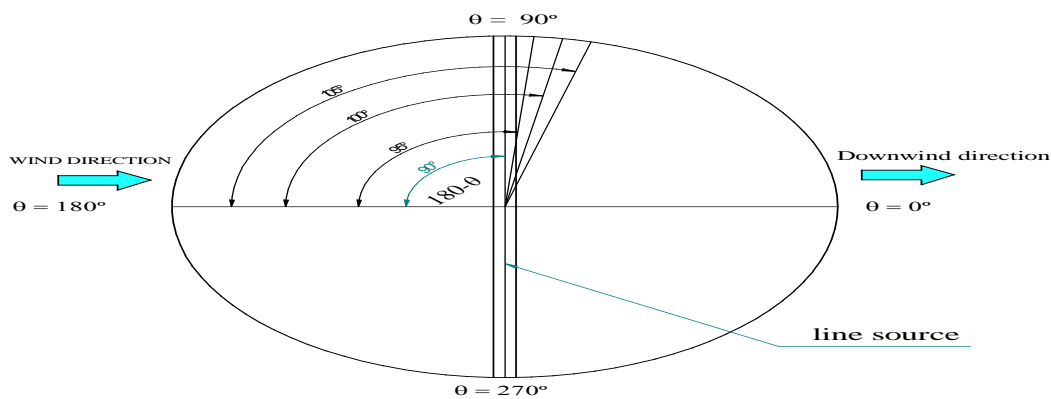

Fig. 3: Orientation of line source with respect to wind flow

2.3. Experimental configuration in the wind tunnel

For the present study, buildings model made of wood cubical in shape had been arranged on the floor of the tunnel from line source to entire downwind section of the tunnel. The buildings model had been arranged downwind direction of the line source such that the row of buildings was at 70 mm (1H) for double storied buildings. This arrangement ensured that the line source was located in amidst of the buildings model. Macdonald et al. (1997) characterised the buildings arrangement for arrays of cubical elements by plan area density, λ_{ar} . For regular arrays of cubical elements, the plan area density λ_{ar} is related to the gaps between cubes S and their height H by (eq 1)

$$\lambda_{ar} = \frac{1}{(1 + S/H)^2} \tag{1}$$

Where, S= Space between two consecutive array element

Based on plan area density different flow regimes have been defined for arrayed cubical blocks arrangement. The characteristics of these main flow regimes are presented in Table.1. The present studies have been conducted an isolated roughness flow regime for double storied buildings for the plan area density as per the Table 2.

Table. 1: Characteristic of the flow regime (Macdonald et al. [1997])

Flow regime	Array spacing	Plan Area density (%)
Isolated Roughness flow	S/H>2.0-2.5	$\lambda < 8-11$
Wake Interference Flow	1.0-1.5<S/H<2.0-2.5	8-11< λ <16-25
Skimming Flow	S/H<1.0-1.5	16-25< λ

Table 4.3 Characteristic of the flow regime for the double storied buildings model

Sl. No.	Average building height (m)	Scale	S/H (>2.0–2.5)	λ_{ar} (%) (<8–11)	Width	Prototype cubical model H (mm)
1	7	1:100	2.00	11.0	W=H	70

For double storied buildings, cubical blocks having a height (H) of 70 mm with a spacing (S) between elements of 140 mm, and the plan area density was found to be 11.0% (or S/H=2.0). As per the flow regime suggested by Macdonald and Griffiths [1997] in Table 4.3, the prototype cubical models used for the experiment are made of wood at a geometric model scale of 1:100, which represents a real building's height of 7 m. Dimensions of the models are 70 mm (L) × 70 mm (W) × 70 mm (H). The size for both the inline array configurations was 6×6 arrays. Fig. 4. Show a plan view of experimental buildings arrangement for inline array for double storied buildings.

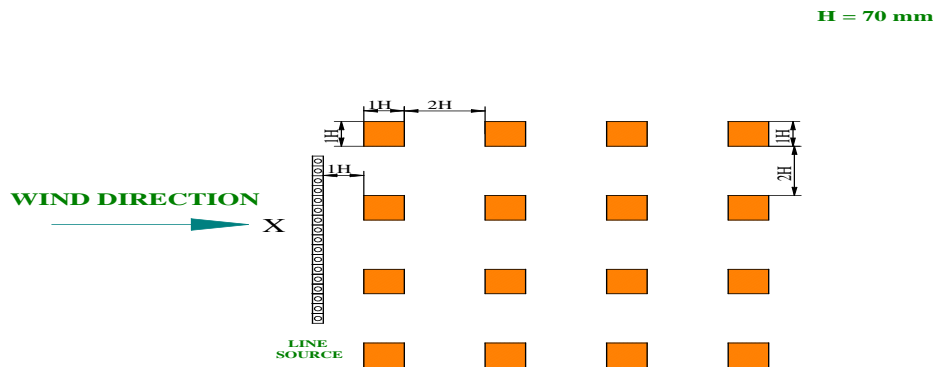

Fig. 4. Plan view of experimental buildings model inline array arrangement for double storied buildings

III. RESULTS AND DISCUSSIONS

3.1. Effects of the wind direction observed in the wind tunnel

Series of experiments have been carried out in which the wind direction varied in steps of 5° for selected orientation of line source at 95°, 100° and 105° as per the scheme shown in Fig. 3. Concentration profiles were taken in the central portion up to 70 mm away from side walls to avoid side wall boundary layer effects for the double storied buildings model of inline array configurations. The observed normalized concentrations C/C_0 versus selected lateral width Y/H of the tunnel are plotted at Z/H=5.7 to quantify the effect of wind direction as shown in Figs.5- 7 for the selected downwind distances.

From the figures, it is revealed that measured concentration at Y=10H is relatively higher than other lateral locations up to downwind distance between 119H and 238H for measured orientation of the line source. This trend due to plume is transported along the wind direction as the orientation of line source is increased. This may be attributed due to higher recirculation region in the double storied buildings model. This type of behavior has also been reported by Mavroidis and Griffiths [2007] in their work.

At far away from line source, measured concentration distribution at downwind distances of 298H and 357H showed a reasonable uniformity along lateral width of the tunnel both at centerline and at either side of the centerline. In other words, nearly the same concentration distribution was observed at far away downwind distances of 298H and 357H due to downwash of the tracer concentration (material), which is released in the wind tunnel (reported by Macdonald and Griffiths [1997]). Further, it was concluded that the maximum lateral concentration shift to upward the wind direction as orientation of line source is increased for inline double storied buildings model configuration.

a) X=119H

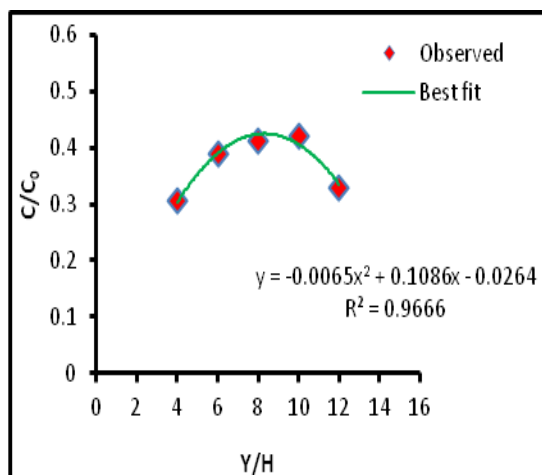

b) X=179H

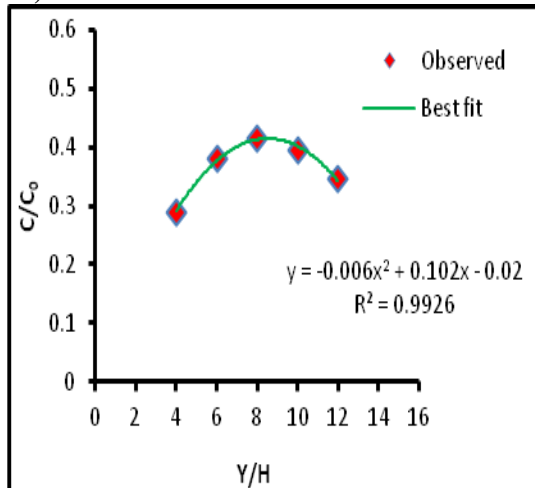

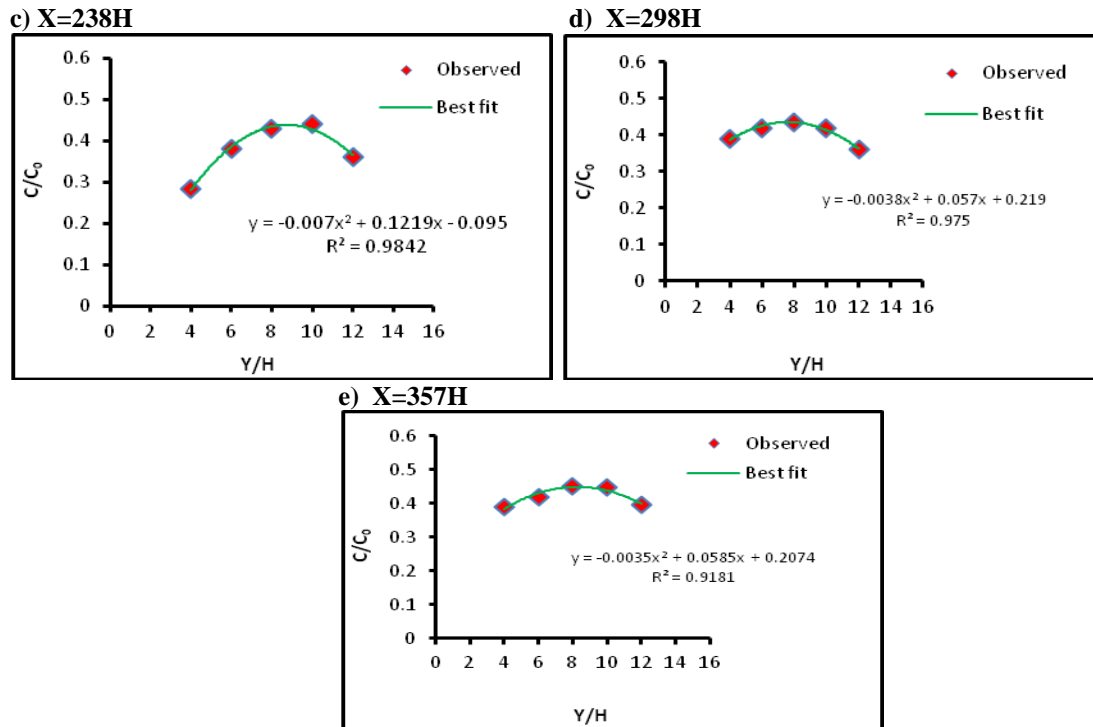
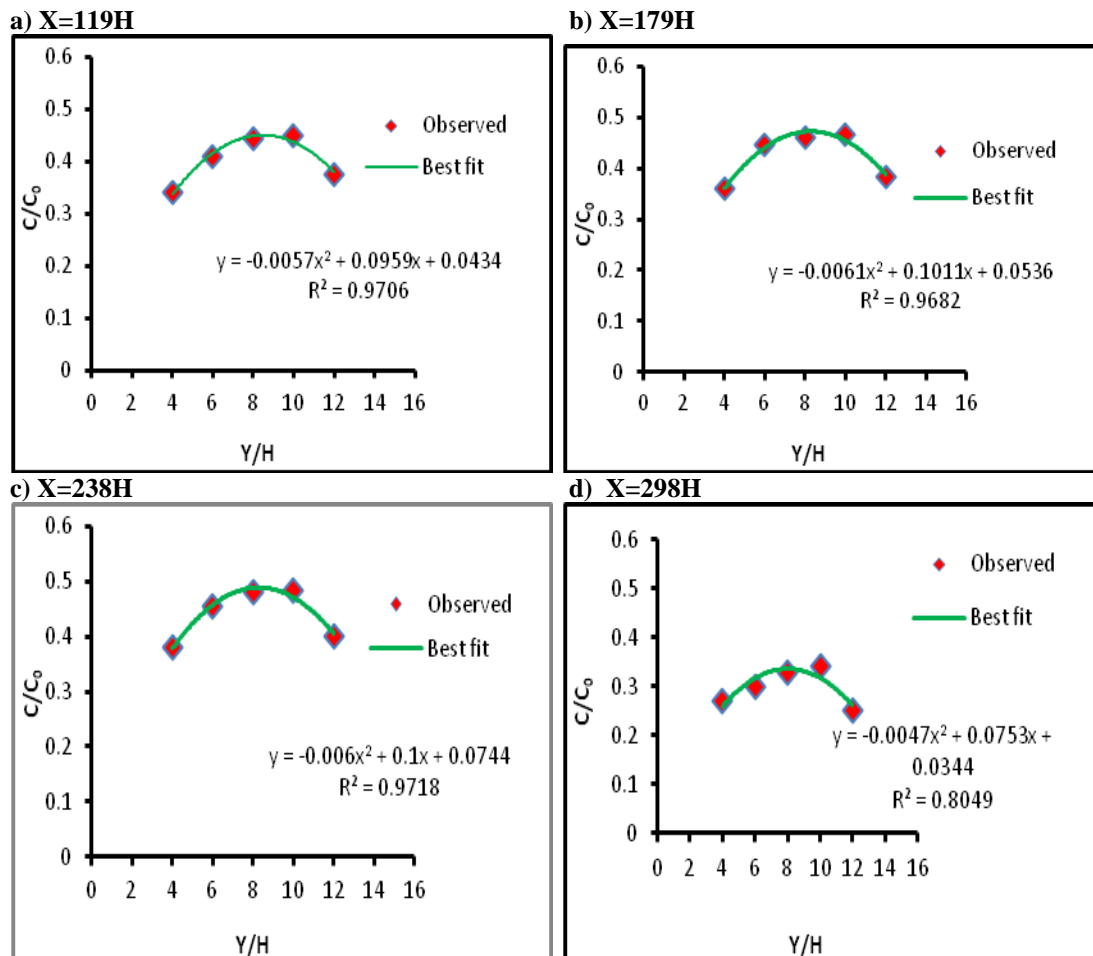

Fig. 5 Concentration profiles for 95°-orientation of line source for double storied buildings model configuration at Z/H=5.7.



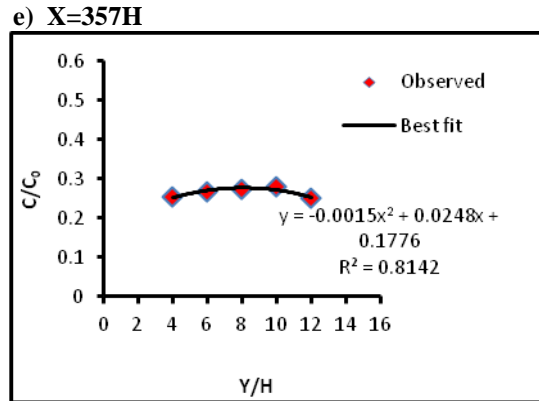

Fig. 6. Concentration profiles for 100°-orientation of line source for double storied buildings model configuration at $Z/H=5.7$

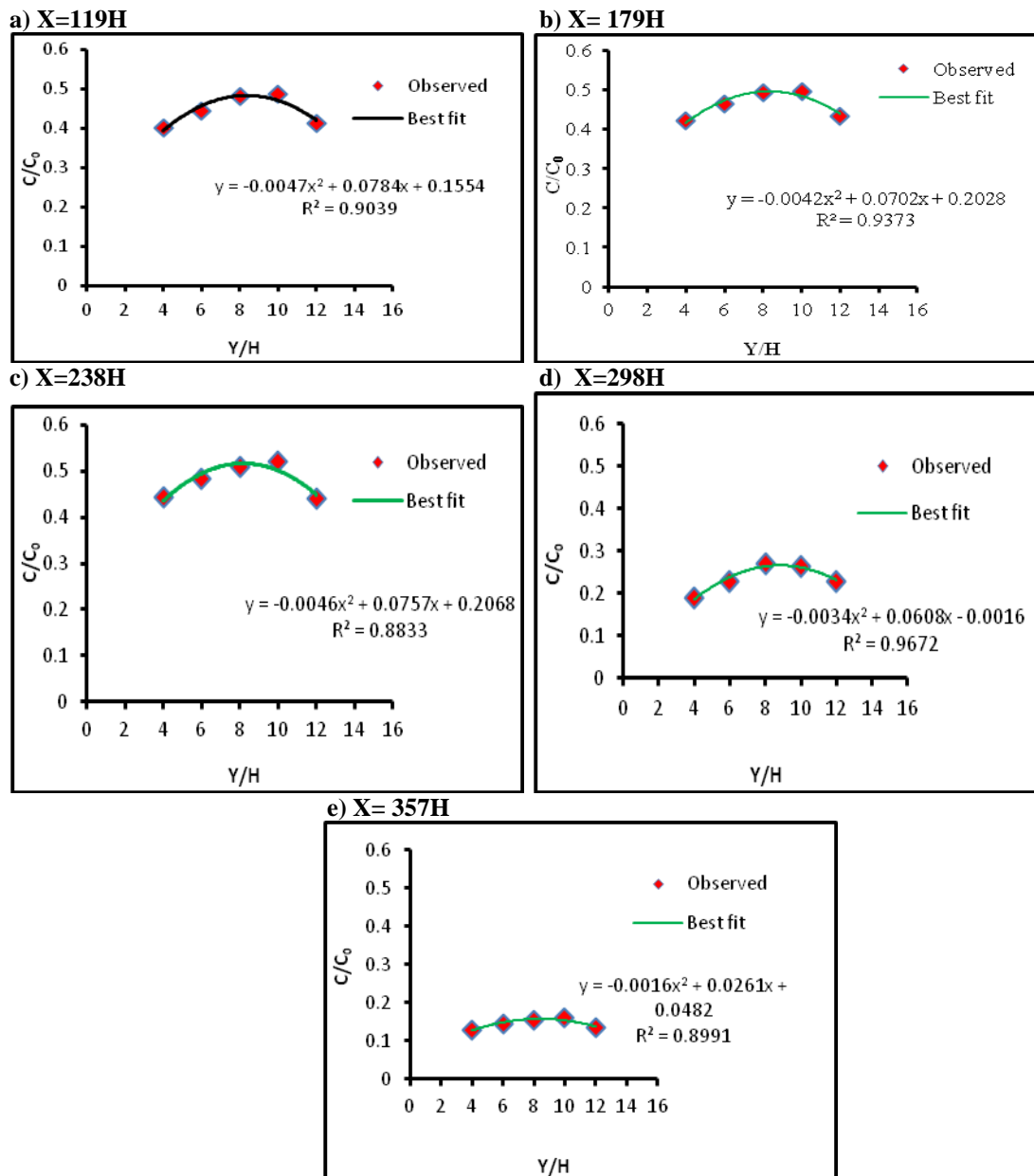

Fig. 7. Concentration profiles for 105°-orientation of line source for double storied buildings model configuration at $Z/H=5.7$

3.2 Comparison of concentration profiles for selected wind direction and downwind distances

Comparisons of lateral concentration profile for different orientations of inline array double storied buildings model configuration have been made at selected downwind distances. In Figs. 8 concentration profiles for each were plotted between normalized concentration and lateral distances for selected downwind distances of $X=119H$, $179H$, $238H$, $298H$ and $357H$ for the selected vertical height from the tunnel floor. A comparison was made to see the variation with each orientation of the line source.

From the figures, it can be observed that measured concentration at $Y=10H$ was relatively higher compared to the centerline (at $Y=8H$) as well as either side of the centerline for all the measured orientations at downwind distances between $119H$ and $238H$. It can be seen from the figures that concentration distribution shift to upward the downwind as orientation of line source is increased (positive values) in inline double storied buildings model configuration. A similar trend was also reported by Mavroidis and Andronopoulos [2007] and Macdonald et al. [1998] in their work. Also, from Fig. 8 it is evident that due to higher recirculation region in the double storied buildings model, irregular concentration distribution trend was observed at downwind distances of $298H$ and $357H$ irrespective of orientation of line source.

It can be concluded, the wind tunnel results showed that concentrations at downwind distances between $119H$ and $238H$ decreased as the wind direction increases (positive values) for measured orientation of line source in double storied buildings model configuration. A similar trend has been reported by Mavroidis and Andronopoulos [2007] in their work.

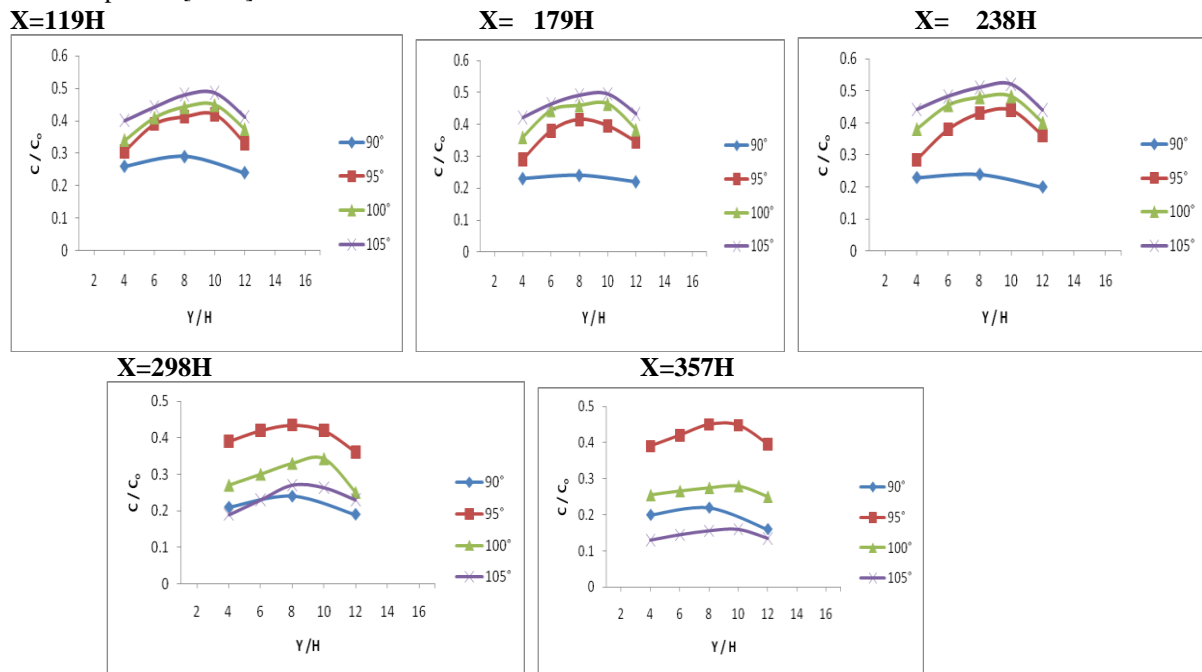

Fig. 8: Comparison of lateral concentration profiles for selected wind direction

3.3. Comparison of vertical spread parameter (σ_z) for single and double storied inline array configuration with field data

The problem of plume dispersion around urban buildings has been investigated by physical modeling using arrays of buildings-like obstacles at a scale of 1:100 in a boundary layer wind tunnel for double storied buildings and compared with the field data reported by Macdonald et al. [1998]. The particular effect of obstacle width-to-height ratio (S/H) was examined for a fixed obstacle plan area density. Figs. 9 shows a comparison of vertical spread parameter (σ_z) values obtained for double storied inline array configuration with reported field data. Experimentally obtained non-dimensionalized concentration with cubic height (H) (i.e., σ_z/H) values was plotted against downwind distances (X). Experimentally obtained values of σ_z/H for the double storied buildings model of inline array configuration have been compared with the field data reported by Macdonald et al. [1998].

In comparison, experimentally observed σ_z values are below the field values reported by Macdonald et al. [1998]. They were best fitted with power-law profiles. The non-dimensional concentration for both the field and wind tunnel results of double storied inline buildings configuration seems to be more or less uniform. Values of vertical spread parameters for double storied inline array configuration and field data were followed a similar trend but inline array configuration of double storied buildings model, non-dimensional concentrations were typically twice larger compared to the field data reported by Macdonald et al. [1998]. This is attributed to the fact that the tracer material is quite concentrated in the recirculation region in inline array configuration of the double storied buildings model.

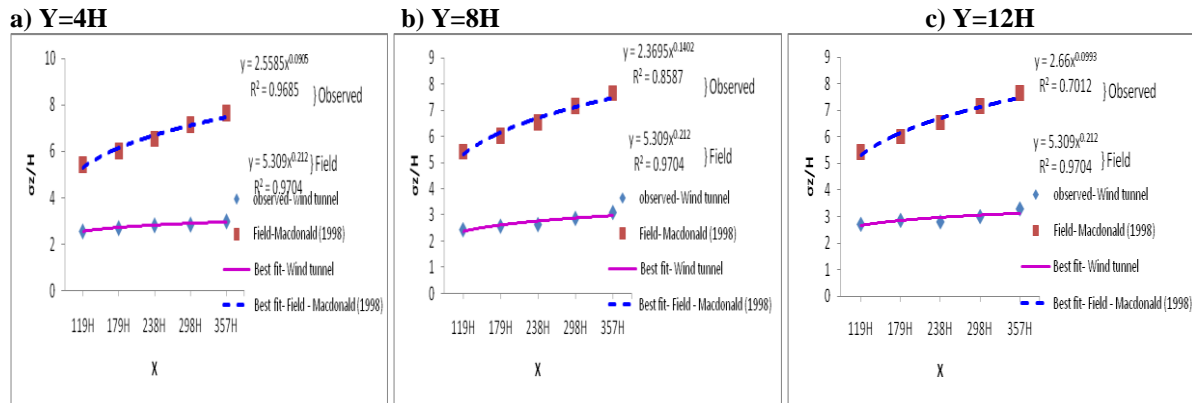

Fig. 9: Comparison of σ_z values for double storied inline array configuration with field data.

IV. CONCLUSIONS

The observed normalized concentrations C/C_0 versus selected lateral width Y/H of the tunnel are plotted at $Z/H=5.7$ to quantify the effect of wind direction for the selected downwind distances. It is revealed that measured concentration at $Y=10H$ is relatively higher than other lateral locations up to downwind distance between $119H$ and $238H$ for measured orientation of the line source. This trend due to plume is transported along the wind direction as the orientation of line source is increased. This may be attributed due to higher recirculation region in the double storied buildings model. This type of behavior has also been reported by Mavroidis and Griffiths [1996] in their work.

At far away from line source, measured concentration distribution at downwind distances of $298H$ and $357H$ showed a reasonable uniformity along lateral width of the tunnel both at centerline and at either side of the centerline. In other words, nearly the same concentration distribution was observed at far away downwind distances of $298H$ and $357H$ due to downwash of the tracer concentration (material), which is released in the wind tunnel (reported by Macdonald and Griffiths [1997]). Further, it was concluded that the maximum lateral concentration shift to upward the wind direction as orientation of line source is increased for inline double storied buildings model configuration.

It can be concluded, the wind tunnel results showed that concentrations at downwind distances between $119H$ and $238H$ decreased as the wind direction increases (positive values) for measured orientation of line source in double storied buildings model configuration. A similar trend has been reported by Mavroidis and Andronopoulos [2007] in their work.

In comparison, experimentally observed σ_z values are below the field values reported by Macdonald et al. [1997]. They were best fitted with power-law profiles. The non-dimensional concentration for both the field and wind tunnel results of double storied inline buildings configuration seems to be more or less uniform. Values of vertical spread parameters for double storied inline array configuration and field data were followed a similar trend but inline array configuration of double storied buildings model, non-dimensional concentrations were typically twice larger compared to the field data reported by Macdonald et al. [1997]. This is attributed to the fact that the tracer material is quite concentrated in the recirculation region in inline array configuration of the double storied buildings model. A similar trend has been reported Krishna, M.K and Gowda [2015]

REFERENCES

- [1]. Hosker R P., (1984). Flow and diffusion near obstacles, Atmospheric science and power production, 7, 241-326
- [2]. Hunt, J.C.R. and Fernholz, H., (1975). Wind tunnel simulation of the atmospheric boundary layer, A report on EUROMECH 50, Journal Fluid Mechanics, v. 70, pt. 3, pp. 543-559.
- [3]. Meroney, R.N., Pavageau, M., Rafailidis, S. and Schatzmann, M. (1995). Study of line Source characteristics for 2-D physical modelling of pollutant dispersion in street canyons, journal of Wind Engineering and Industrial Aerodynamics, Personal Communication.
- [4]. Davidson M.J., Mylne K.R., Jones C.D. et.al. (1995). Plume dispersion through large groups of obstacles, Atmos. Environ., 29, 3245-3256.
- [5]. Theurer, W., Plate, E.J. and Hoeschele, K., (1996). Semi-empirical models as a combination of wind tunnel and numerical dispersion modelling Atmospheric Environment, vol. 30, No. 21, pp. 3583-3597
- [6]. Macdonald, R.W. Griffiths, R.F. Hall D.J. (1998). A comparison of results from scaled field and wind tunnel modeling of dispersion in arrays of obstacles, Atmos. Environ., 32 (22) 3845-3862
- [7]. Mavroidis I, Griffiths R F., (1996). Dispersion of Airborne Pollutants in Vicinity of Isolated Obstacles, In Proceedings of the International Conference, Protection And Restoration Of The Environment III, Chania, Greece.
- [8]. Counihan, J., (1969). An improved method of simulating atmospheric boundary layer in a wind tunnel, Atmospheric Environment, 3, 197-214.
- [9]. Gartshore, I.S., (1977). De Cross, K.A. Roughness element geometry required for wind tunnel simulation of the atmospheric wind, Transactions of the ASME, Journal of Fluids Engineering, ASME, 99, 480-485.

- [10]. Gowda. (1999).Wind tunnel simulation study of the line source dispersion in the near-field of roadways under heterogeneous traffic conditions, Ph.D. Thesis, IIT, Delhi.
- [11]. Macdonald R.W., Griffiths R.F., (1997).Field experimental of dispersion through regular arrays of cubic structures, Atmos. Environ., 31, (6), 783–795.
- [12]. Mavroidis, I., Andronopoulos, S., (2007).Atmospheric dispersion in the presence of a three-dimensional cubical obstacle: modelling of mean concentration and concentration fluctuations, Atmospheric Environment, 41, 2740–2756
- [13]. Krishna,M.K., Gowda.,(2015) An experimental study on vehicular emission dispersion through single storied building model configurations, International Journal of Engineering Science Invention V-4, I- 10,19-25.