

Cooperative Communication in UWB OFDM Systems

J Sravanthi¹, S Swathi²

¹(Assistant Professor, ECE Department, TKRCET, Hyderabad)

²(Assistant Professor, ECE Department, TKRCET, Hyderabad)

Abstract: Ultra Wide Band (UWB) technology is a fast emerging technology for short distance wireless communication. UWB plays a preeminent role in the short range wireless systems, due to the advantages of high speed, low power consumption and very high security. Methods/Statistical Analysis: With cooperative communication as a decisive member in its side this paper proposes cooperative MB-OFDM communication using effective grouped relays in multichannel with use of Dual Carrier Modulation (DCM) for UWB systems. We can attain maximum diversity by using simple Maximum Likelihood (ML) receiver without reduction of data rate as its found using almouti coding which is most used to provide diversity in cooperative communication. Findings: The Proposed method's resulting diversity is observed using outage probability as a basic parameter and also how the outage probability varies in accordance to threshold power. Application/Improvements: The results shows an improved BER versus SNR with effect of CFO is considered and the improvement in channel capacity and data rate of various different modulation schemes is obtained by varying SNR and distance.

Keywords: Dual Carrier Modulation (DCM), MultiBand Orthogonal Frequency Division Multiplexing (MB-OFDM), Single-Input Multi-Output (SIMO), Multi-Input Multi-Output(MIMO), Ultra Wide Band (UWB)

I. Introduction

In the near future, the increasing need for high speed wireless communication leads to applications such as Wireless USB (W-USB) and Wireless High-Definition Media Interface (HDMI), the demand for indoor Wireless Personal Area Network (WPAN) communication. UWB is gathering interests as a short-reach transmission system, among the various technologies which aimed to provide high data rate wireless links. UWB can fulfill the requirements for low power transmission and high-speed digital home networks. Currently, research on UWB systems for high data rate transmission in the indoor wireless channel environment is being investigated. The MBOFDM based UWB system was proposed by the Multi-Band OFDM Alliance (MBOA) for providing high data rate wireless communication links. The MB-OFDM UWB system is supported by a lot of association and business organizations due to the low transmission power and high data rate transmission. Ultra-wideband communications different from other communication techniques because it uses very narrow RF pulses between transmitters and receivers. These narrow pulses communicates a very wide bandwidth and provides many advantages, such as large throughput, covertness, robustness to jamming, and coexistence with existing radio services.

The advantage of a large bandwidth and the capability of using multiuser systems provided by electromagnetic pulses were never considered earlier. After fifty years after Marconi, modern pulse-based transmission was introduced in military applications in the form of impulse radars for secure communications. However, the latest advancement in micro processing and switching techniques in semiconductor technology has made UWB for commercial applications⁵. As interest in the commercialization of UWB has increased over the past several decades, Figure 1 shows the developments of UWB ^{6,7}.

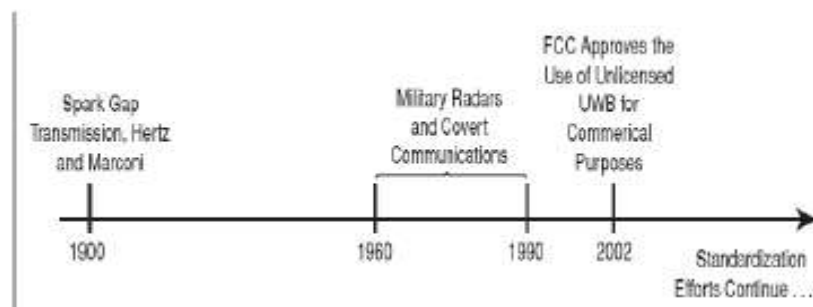

Fig 1: History of UWB developments.

II. Cooperative Communication

MIMO technology is widely applied to improve the throughput and reliability of wireless communication links. As depicted in Figure 2, the concept of a MIMO system is to figure and merge the transmitted signals from multiple wireless paths between the multiple transmit and receive antennas which are spatially separated.

The multiplexing technique used by MIMO increases the bandwidth and communication range. MIMO uses the extra pathways to transmit more information and then recombines the signals at the destination to reduce the overall system Bit Error Rate (BER), thus improving the system reliability. However, in practice, a MIMO system could have some disadvantages. One of the main drawback is the limitation of the transmitter and receiver devices (may be portable) can only be equipped with a single antenna due to their tiny physical size, which does not facilitate the space of at least a half wavelength to install multiple uncorrelated transmit antennas. The basic ideas behind cooperative communication were analyzed in a three node network with one source, one relay and one destination by Cover and El Gama8.

Figure 3 illustrates one source node and one relay transmitting independent copies of a signal to the base station (destination). A single antenna device cannot generate spatial diversity. Nevertheless, the fading between two agents which is statistically independent. If one node is able to hear from the other and forward a modified version of the message in its own way, the spatial diversity can be generated to effectively combat against the detrimental effects of channel fading. As shown in Figure 3, the relay channel generates an individual path between the user and the base station. The relay channel can be an alternative channel between the source and destination apart from the existing direct channel. The signal processing at the receiver relay node is an important aspect of the cooperative communication. The various protocols expose different processing schemes in cooperative communications. The fixed relaying schemes and adaptive relaying schemes are types of the cooperative communication protocols. In fixed relaying, the channel resources are divided in a fixed (deterministic) manner between the source and the relay. The signal processing at the relay depends on the protocol that is used. In a fixed Amplify-and-Forward (AF) relaying protocol, the relay processes the received signal and transmits the amplified signal to the destination. Another method of processing is the fixed Decode-and-Forward (DF) relaying protocol, where the relay node decodes the received signal, encodes it again and then retransmit it to the receiver9,10.

A) Cooperative Protocols:

To avoid the interference between the two phases either TDMA or FDMA cooperation strategy can be used. In phase 1, the source sends information which is received by the relay node as well as the destination at the same time. In phase 2, the relay receives the signal from the source and retransmits the information to the destination. Generally in a relay channel, the transmitted power of the source is P_1 and the transmitted power of the relay is P_2 . The special case where the source and the relay transmit with equal power P is considered. In phase 1, the source broadcasts its information to both the destination and the relay. The received signals $y_{s,d}$ and $y_{s,r}$ at the destination and the relay, respectively, can be written as

$$y_{s,d} = \sqrt{P} s_d x + n_{s,d} \quad (1)$$

$$y_{s,r} = \sqrt{P} s_r x + n_{s,r} \quad (2)$$

In which P is the transmitted power at the source, x is the transmitted information symbol, and $n_{s,d}$ and $n_{s,r}$ are additive noises. $h_{s,d}$ and $h_{s,r}$ are the channel coefficients from the source to the destination and the relay, respectively. They are modeled as zero-mean, complex Gaussian random variables with variances δs_d^2 and δs_r^2 , respectively. The noise terms $n_{s,d}$ and $n_{s,r}$ are modeled as zero-mean complex Gaussian random variables with variance N_0 . In phase 2, the relay forwards a processed version of the source's signal to the destination, and this can be modeled as

$$y_{r,d} = h_{r,d} (q y_{s,r}) + n_{r,d} \quad (3)$$

B) Decode and Forward Protocol:

The DF concept was firstly proposed in the literature as illustrated in Figure 4, the DF protocol allows the relay to decode the received message from its partner, afterwards re-encode and retransmit it to the destination.

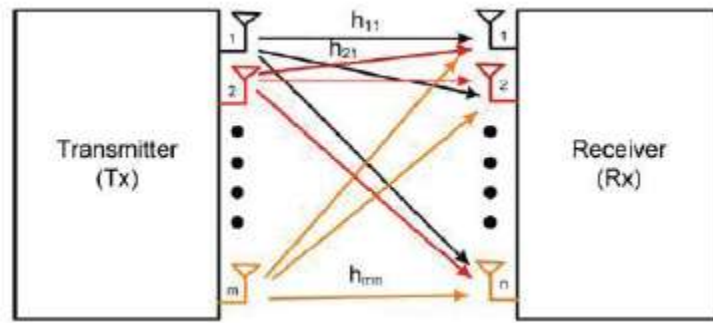

Fig 2: MIMO system

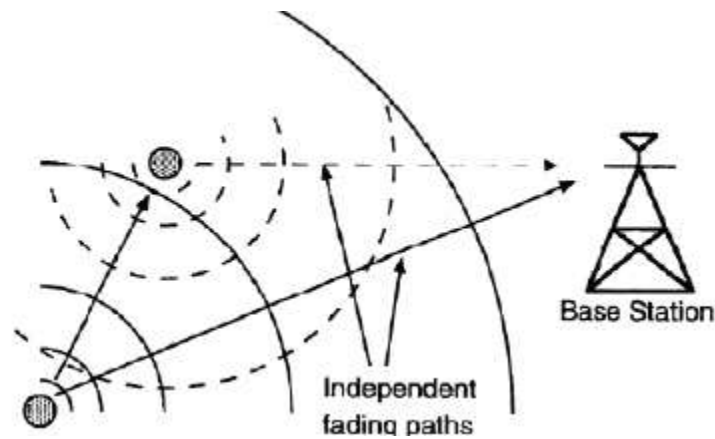

Fig 3: Cooperation between Nodes

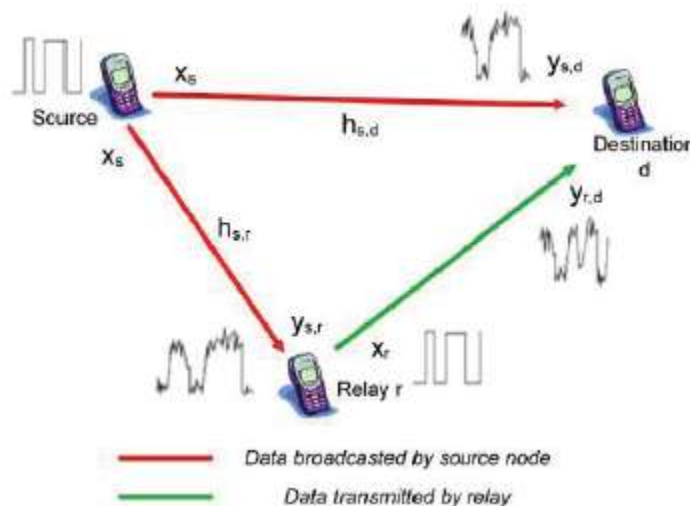

Fig 4: Decode and Forward Model

III. OFDM

In order to increase the spectrum utilization of the Frequency Division Modulation (FDM) technology, the design goal of the system was to send the data in a series of multi-path fading wireless channels. The system used 20 sub-carriers, with differential Quadrature Phase Shift Keying (QPSK) modulation. The spectrums of the sub-carriers overlap, but the sub-carriers are orthogonal with one another. So, the spectrum efficiency could be greatly improved. The system embodied the core idea of the OFDM technology, and could be seen as the embryonic form of the OFDM system. In order to limit the system spectrum, Chang analyzed how to make the sub-carriers hold orthogonal in the MB-OFDM communication system. Later, the solution of implementing the multi-carriers base-band modulation and demodulation modules with discrete Fast Fourier Transformation (FFT) transform. With this solution, it would no longer have to use the analog front-end before each sub-carrier.

As a result, it would greatly reduce the complexity of the multi-carrier system, and make great contribution to the OFDM evolution.

In UWB communication, the transmitted signal can be spread over a very large bandwidth with extremely low Power Spectral Density (PSD). The USA Federal Communications Commission (FCC) allotted 7500 MHz RF spectrum in 3.1-10.6 GHz band for unlicensed use for the UWB devices in 2002 and limited the UWB Effective Isotropic Radiated Power (EIRP) to -41.3 dBm/MHz. The IEEE 802.15a emerged working party for Wireless Personal Area Network (WPAN), which were Direct- Sequence (DS) UWB (Fisher et al., 2005) and MB-OFDM (Batra, et al., 2004a). Meanwhile with the IEEE standardization attempted, the Multiband OFDM Alliance Special Interest Group (MBOA-SIG) came ahead to standardize their UWB system based on MB-OFDM. In 2005, the WiMedia Alliance working with European Computer Manufacturers Association (ECMA) introduced the establishment of the WiMedia MB-OFDM UWB radio platform as their global UWB PHY and Media Access Control (MAC) standard, ECMA-368, based on the previous MBOA-SIG proposal (Multiband OFDM Alliance, 2004) with small changes. An updated version of ECMA-368 was published in December 2008 by including the regulatory flexibility and maintained as ISO/IEC 26907 (ECMA, 2008). ECMA-368 specification includes an MB-OFDM system which occupies 14 bands with a bandwidth of 528 MHz for each band. This method is used to efficiently capture the multipath energy with a single RF chain. The first 12 bands are grouped into 4 band groups (BG1-BG4), and the last two bands are grouped into a fifth band group (BG5). A sixth band group (BG6) containing band 9, 10 and 11 which is also defined within the spectrum of BG3 and BG4, in agreement to usage within worldwide spectrum regulations. The main advantage of the grouping is that the transmitter and receiver can process a smaller bandwidth signal taking advantages from frequency hopping. Figure 5 depicts the band group allocation.

A) Structure of MB-OFDM UWB: The above Figure 6 shows the structure of MB_OFDM. Series-to-parallel (S/P) and Parallel-to-series converter The S/P converter is used to split up a serial bit stream into a group of parallel bit streams. On the contrary, the P/S converter is to combine the parallel bit streams into a serial bit stream. Convolutional encoder and Viterbi decoder The convolutional encoder is used to encode the parallel bit streams to create robust signals and provides better bit error performance when the channel SNR is low. The Viterbi decoder is paired with the convolutional encoder. It is used to decode the convoluted signal.

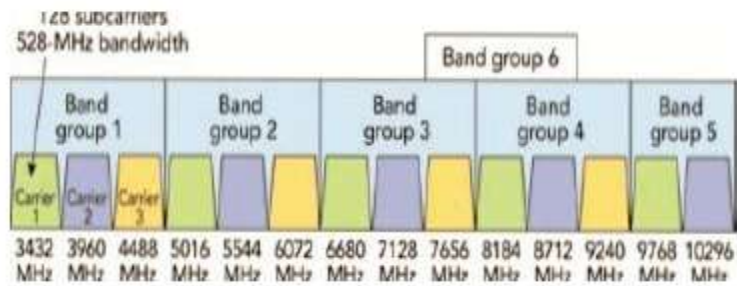

Fig 5: Band Group Allocation

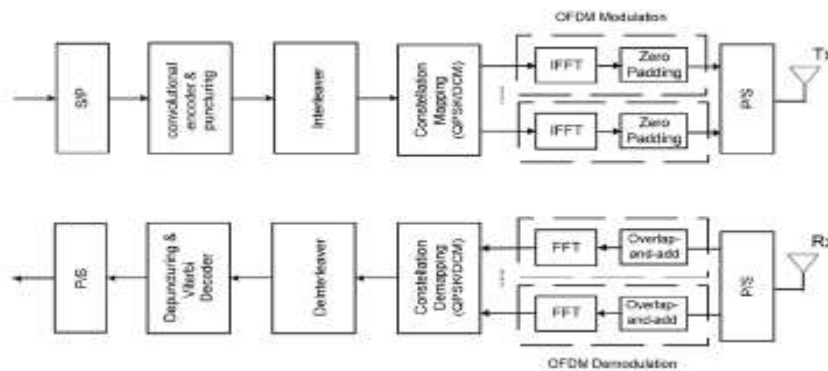

Fig 6: Structure of MB ofdm UWB

Interleaver: The coded signal is interleaved prior to constellation mapping to avoid the burst errors during the wireless transmission. Constellation Mapping: Various modulation techniques can be applied in the constellation mapping block, Such as QPSK and DCM depending on different requirements of the data rate in the System.

Inverse Fast Fourier Transform (IFFT): The modulated data is inserted with 10 guard, 12 pilot subcarriers and 6 nulls, then the signals are processed by the IFFT block and are converted from frequency domain to time domain to form an OFDM symbol.

Zero-padding Suffix: Conventional OFDM systems use a Cyclic Prefix (CP) to against the multipath effect. However, it may cause ripples in the average Power Spectral Density (PSD). In the case of MB-OFDM UWB, it could be as large as 1.5dB. In MB-OFDM UWB systems, Zero-Padded Suffix (ZPS) is used instead of the conventional CP to reduce the ripples in the PSD, which essentially reduces the power-back off problem at the transmitter, and thus the system is able to achieve the maximum possible transmission range. After this guard insertion, the MB-OFDM symbols will be transmitted through the UWB channel, which is specified in the next section. The received signals can be recovered by applying an inverse process of all the techniques mentioned above¹².

IV. DC-OFDM

Dual Carriers-OFDM (DC-OFDM) UWB system has many similar points with the traditional MB-OFDM UWB system. In this system, the frequency band can be divided into several sub-bands. Figure 7 and 8 gives the DC-OFDM frame work and constellation diagram. Each frequency band is less than 264MHz and form one OFDM symbol. It is composed by many orthogonal sub-carriers¹³.

A) Cooperative Communication with Grouped Relays:

The cooperative communication with grouped relays depends on the Decode and Forward (DF) protocol shown in Figure 9. The relays are grouped into G groups with the index G_j for $j=1, \dots, G$, the Phase I indicates that the broadcasting from the source to the relays, which is assumed perfect and share only one frequency band, and Action I indicates certain additional coding by the source on the original data¹⁴. In Phase II is for the relays and the destination, and Action II indicate few additional coding by the relay on the decoded data. The relays also contact each other occasionally to organize themselves which will be explained later¹⁵. If any relay fails to decode the information from the source, this relay is considered as inactive for this cooperative communication. else, the relay is active. Hence assuming the source broadcasts on Band #b, the j-th relay group transmits signals to the destination on Band #bj.

V. Results

The digital base band of the PHY layer in MB-OFDM UWB system was implemented, first design the system in MATLAB and perform the following analysis.

Data Rate Vs Distance: The different modulation schemes are compared as shown in Figure 10. The data rate for various distances is measured by assuming the signal propagation takes place in free space.

The free-space attenuation A_m is expressed as:

$$A_m(f) = \frac{(4\pi)^2 D^2 f^2 L}{G_T G_R C^2} \tag{4}$$

Where D is distance of propagation, G_T and G_R are transmitter and receiver antenna gain, f is frequency of operation and c is speed of light. Assumption made for the simulations is $L = 1$, which indicates no loss in the system hardware. The relation between distance of propagation, D and data rate, R_b is given by:

$$D^2 = \frac{G_T G_R c^2}{(4\pi)^2 R_b} \frac{\int_{f_L}^{f_H} \frac{P_s(f)}{f^2} df}{M_S SNR_{spec} \frac{1}{2} F_{sys} kT_0} \tag{5}$$

From above it is observed that data rate is inversely proportional to the distance of propagation. It is seen that DCM maintains high data rate with the increase in propagation distance also.

Channel Capacity vs. SNR: The channel capacity of the various systems in UWB is measured using Shannon's Capacity and it is given as below and the channel capacity against SNR comparison.

$$\text{Capacity} = \text{bandwidth} * (1+s/n)$$

From above it is observed that the channel capacity increases with the increasing SNR. For example at SNR = 14 dB the capacity of the various channels is as follows DCM=15.73,16-PPM=11.88,16-PAM=7.88,QAM=4.70.

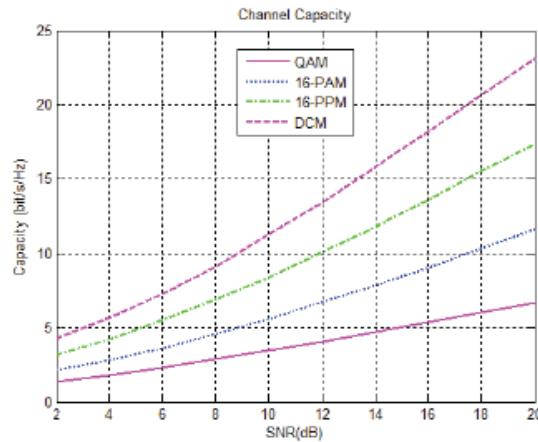

Fig 11: Channel Capacity vs SNR

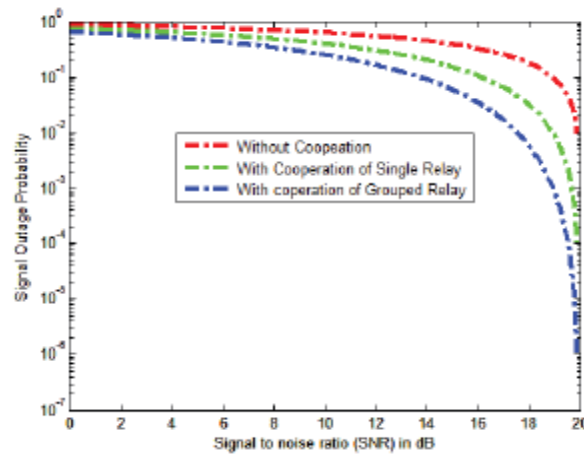

Fig 12: Outage Probability vs SNR

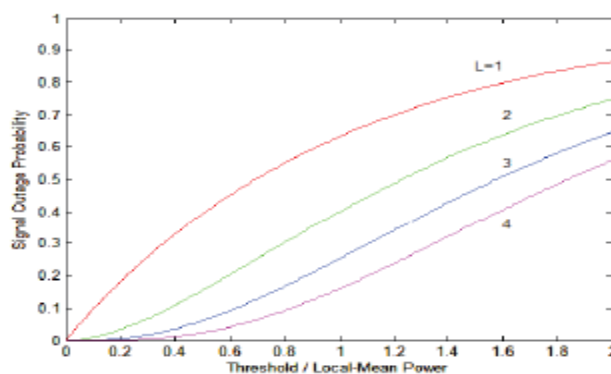

Fig 13: Outage Probability vs Threshold/local-mean power

Outage Probability Vs SNR: Outage Probability effect against SNR is an important analysis to be observed and here we observe the effect of SNR on different modes of system they are system with Grouped relay, with single relay and which does not follow cooperative communication and these are observed as shown in Figure12. We can infer that the outage probability is inversely proportional to SNR and we know that outage can be said as ratio of channel output to the channel input which tells about channel effect and we can clearly say that system with cooperation of grouped relay has less outage value followed by single relay and system without cooperation.

Outage probability vs. Threshold/Local Mean Power: The outage probability is compared with the threshold/local mean power. The threshold power is the noise power of the system which does not affect the output, whereas the local mean power is the one which limits the signal detection as shown in Figure 13.

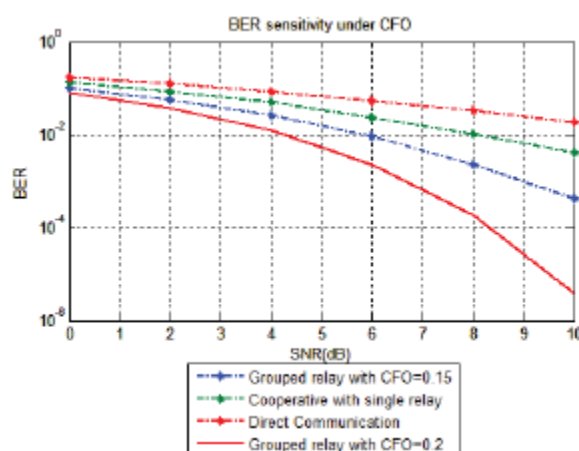

Fig 14: BER Sensitivity under CFO

From above we can infer that as the value of L which is the tapped delay line increases the outage probability decreases so as the tapped delay increases the outage capacity decreases and because of the system with $L=1$ has higher outage probability.

BER vs. SNR under CFO: CFO means Carrier Frequency Offset which is used to identify the original bit rate and its effect on BER vs. SNR is shown in Figure 14 and BER is inversely proportional to SNR. From above figure it is seen that as the CFO increases the effect of BER decreases and observe that if we consider the CFO effect the grouped relay is having very less BER compared to single relay and direct communication and also among grouped relay systems with high CFO has less BER and this can be clearly observed from above if we consider BER values at SNR = 6dB we can infer that grouped relay with CFO = 0.2 has around 0.002 which is very low followed by grouped relay with CFO = 0.15 with 0.009 and then by single relay communication by 0.024 and then by direct communication with 0.05 which clearly states CFO effect greatly reduces the BER effect.

VI. Conclusion

The zero-padding in group relays is proposed in MB-OFDM systems for efficient cooperative communication scheme. The use of group relays in UWB system with cooperative communication is a good alternative to MIMO systems, where the multiple antennas do not have efficient bandwidth coding. The UWB has the advantage of multiple bands, as the system can achieve the gain of full cooperative diversity with linear equalizers even if multiple grouped CFOs exist. Simulation results verify the effectiveness of the proposed grouping in gaining full diversity of MB-OFDM cooperative communication system and also measured the data rate and channel capacity of different modulation schemes which help us in understanding the MB-OFDM system with DCM. This scheme can be applied to an adaptive environment by grouping in order to provide high throughput links for hand-held devices, various consumer electronic appliances, commercial buildings and health care sector.

References

- [1]. Ghavani MLB, Kohno MR. Ultra-wideband signals and systems in communication engineering. 2nd ed. 2007.
- [2]. Nekoogar F. Ultra-Wideband Communications Fundamentals and Applications. 2005.
- [3]. Chong CC, Watanabe F, Inamura H. Potential of UWB Technology for the next Generation Wireless Communications. IEEE Ninth International Symposium on Spread Spectrum Techniques and Applications. 2006 Aug 28-31; 422-29.
- [4]. Manikandan C, Neelamegam P, Divya E. OFDM techniques for MIMO-OFDM system: A review. Indian Journal of Science and Technology. 2015 Sep; 8(22).
- [5]. Y. Multi-Band OFDM Physical Layer Proposal for IEEE 802.15 Task Group 3a, Batra et al. [S]. IEEE P802.15-03/268r3, 2003 Nov 10.
- [6]. Muquet B, Wang Z, Giannakis GB, de Courville M, Duhamel P. Cyclic Prefixing or Zero Padding for Wireless Multicarrier Transmissions. IEEE Trans Commun. 2002 Dec; 50(12).
- [7]. Yang R, Sherratt RS. Dual carrier modulation demapping methods and performances for wireless USB. Proc PGNET'08, Liverpool I, UK, 2008.
- [8]. Lu H, Nikoogar H. A thresholding strategy for DF-AF hybrid cooperative wireless networks and its performance. Proc IEEE SCVT '09, UCL, Louvain. 2009 Nov.

- [9]. Alamouti M. A simple transmit diversity technique for wireless communications. *IEEE Journal on Selected Areas in Communications*. 1998 Oct; 16(8):1451–58.
- [10]. Ma RX, Zhang W. Fundamental limits of linear equalizers: Diversity, capacity, and complexity. *IEEE Trans Inform Theory*. 2008 Aug; 54(8):3442–56.
- [11]. Li X, Ng F, Han T. Carrier frequency offset mitigation in asynchronous cooperative OFDM transmissions. *IEEE Trans Signal Processing*. 2008 Feb; 56(2):675–85.
- [12]. Tran LC, Mertins A, Wysocki TA. Cooperative communication in space-time-frequency coded MB-OFDM UWB. *Proc IEEE VTC'08-fall, Singapore, 2008 Sep 21-24*; 1–5.
- [13]. Kalavani D, Karthikeyan S. VLSI Implementation of Area-Efficient and Low Power OFDM Transmitter and Receiver. *Indian Journal of Science and Technology*. 2015 Aug; 8(18).